



**BioCoTech**  
Biologic Waste Management & Consulting



**GLOBALESCO**

- ENVIRONMENTAL TECHNOLOGY  
THAT REDUCES BIOLOGICAL WASTE  
BY UP TO 90 PERCENT



**BioCoTech AS** is an environmental technology company and leading supplier of installations and solutions for treating and recycling liquid and solid organic waste. All our technical solutions and services can be easily adapted to the varying needs of our customers.

**BioCoTech AS** has more than 10 years of experience, and has excellent business references within its sector. The company has its own engineering and development department at its headquarters in Bergen.



Head Office: Gamlehaugen, Bergen, Norway



Production: Dala Plåtteknik, Sweden





# EFFICIENT AND EASY ON-SITE TREATMENT AND RECYCLING OF ORGANIC WASTE

BioCoTech supplies efficient composting reactors for the catering sector, restaurants, canteens, food production industry and recycling facilities. Our solutions and machines provide a documented reduction of solid biological waste by between 70-90%.

This reduces waste disposal expenses considerably. The remaining waste products can be used as fertilizer and soil additive. The process is extremely environmentally friendly, CO<sub>2</sub> neutral, hygienic, clean and odourless.



## REDUCED VOLUME

BioSpeed reactors reduce the amount of waste by between 70-90% and have a capacity ranging from 48 kg to 6.6 tonnes per day.



## EU STANDARD

The BioSpeed reactor is a new and innovative product that processes organic waste in categories 2 and 3 in accordance with EU guidelines.



## COST-EFFECTIVE

Calculations from supplied installations show annual cost savings of up to 40% for organic waste disposal.



# BioCoTech

Biologic Waste Management & Consulting

**The BioSpeed composting process** is based on a method that enables microbes to function under optimal conditions. All microbes used in the BioSpeed system, including the cellulose-degrading ones, are advanced mesophilic and thermophilic microbes. This means that they work at temperatures of up to 80 degrees Celsius (°C).

The automated processing of waste enables accelerated and continuous decomposition of organic material into powder. Compact machines can therefore provide an overall high processing capacity.



# THIS IS HOW A BIOSPEED COMPOSTER WORKS:

The food waste is emptied into a processing chamber, either directly or through a shredder. The machine processes and aerates the waste using an innovative mixing technique. Microbes break down the waste into a compost powder that is automatically discharged from the processing chamber. The compost powder is hygienic and easy to empty.

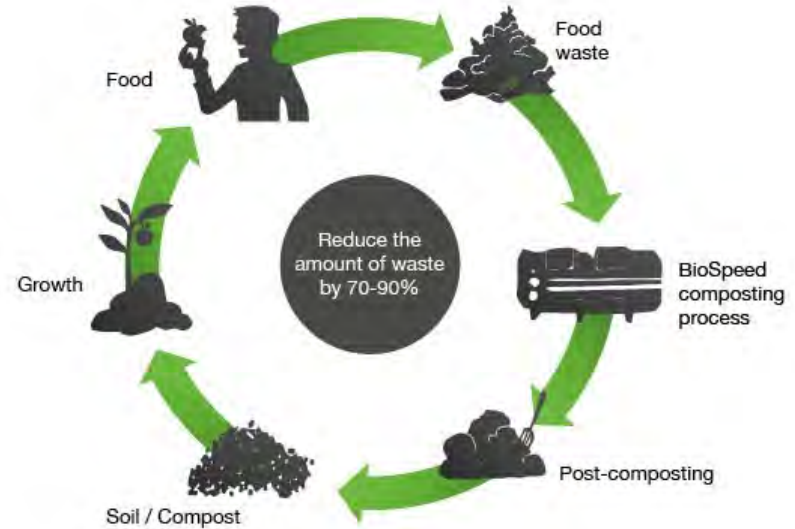

## CAPACITY OVERVIEW

BioSpeed	M1	80-130 litres/ day	48-78 kg/ day *
BioSpeed	M2	160-220 litres/ day	96-132 kg/ day *
BioSpeed	M4	350-400 litres/ day	210-300 kg/ day *
BioSpeed	M18	1800-2200 litres/ day	1080-1320 kg/ day *

All machines can be adapted to meet customer requirements, e.g. recycling unit and bin lift for waste containers. We provide solutions that are suitable for both indoor and outdoor installation.





## TECHNICAL SPECIFICATIONS

- Three chamber solution
- All stainless steel
- Wireless support and control system
- PLC operation
- Adjustable output range
- Energy saving sleep mode
- Alarm and event history in the control panel
- Lamp for error indication



BioSpeed M1



BioSpeed M2



BioSpeed M4

## SAFETY

- Alarm feedback for each engine. Time and component is displayed
- Safety-switch for high temperature loads and heating elements
- Safety-switch open hatch during operation. Agitator stops when door is opened.
- Manual emergency stop by the control panel
- Automatic Standby mode when not in daily use
- Adjustable dispensing time interval
- Automatic repowering after loss of power supply
- Alarm end event recorder in display
- Fault indicator lamp

## OPTIONAL EQUIPMENT

- Lifting rails for waste bin from 120 to 140 liters
- Odor-damping systems as required

## BioSpeed M18



**Biospeed M18** is our largest machine. It is intended for large householding and industrial processing plants

Capacity up to 2200 liter per day per unit

Possibility of paralell coupling and fully automated solutions for up to 5 machines with total capacity of 6,6 tons a day

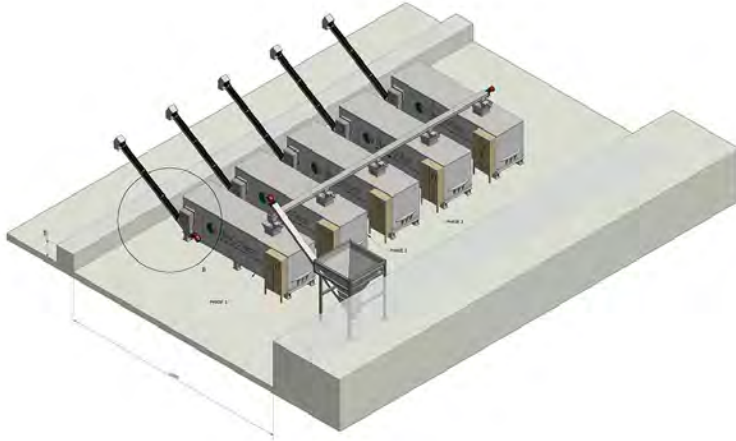

## BioSpeed M18 Composting System

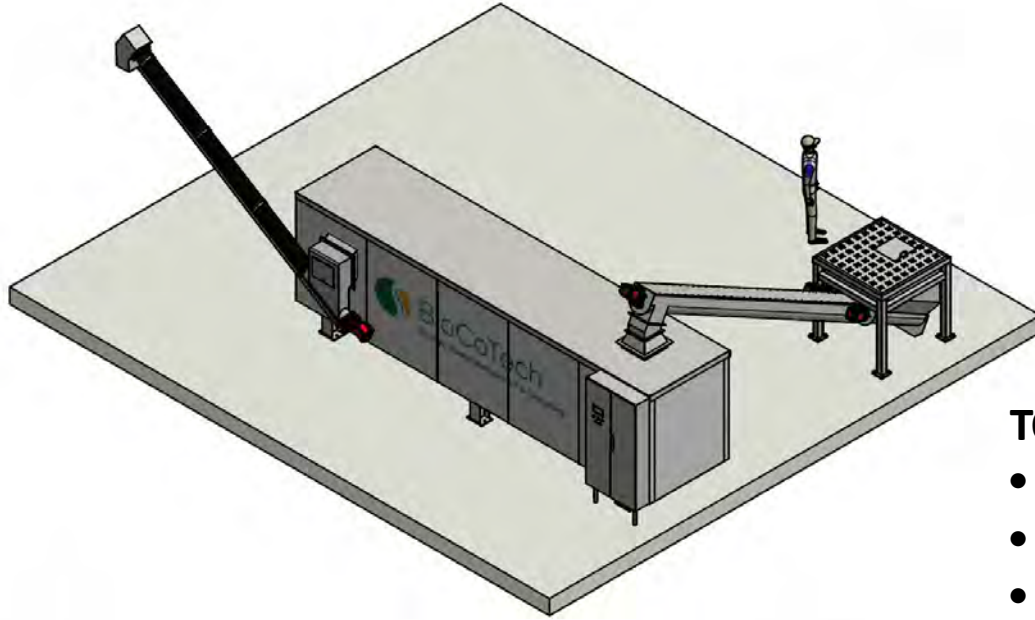

### TOTALLY AUTOMATIC SOLUTION:

- Weight control
- 24 hours continuous operation
- Wireless solution for control and monitoring
- Easy maintenance and installation







BioCoTech

Biologic Waste Management & Consulting

[www.globalesco.com](http://www.globalesco.com)

[info@globalesco.com](mailto:info@globalesco.com)

+306980904949, +30 694495 8668